

## Additional Optical Instruments

### Section 21

### Illumination Systems



### Illumination Systems

The illumination system provides the light for the optical system. Important considerations are the amount of light, its uniformity, and the angular spread of the light as seen by the object.

A projector is the general term for an imaging system that also provides the illumination for the object. This would include systems such as microscopes, slide projectors, enlargers, photolithography systems, copiers, comparators, etc.

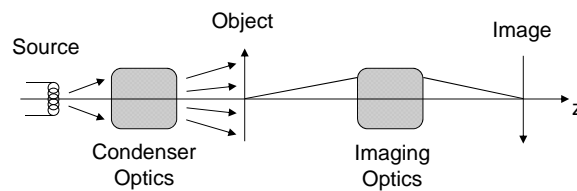

Opaque objects can be included by folding the system about the object and considering the reflection.



### Illumination Classifications

There are three basic classifications of illumination systems:

- Specular illumination – the light source is imaged by the condenser optics into the EP of the imaging optics. Because of its good light efficiency, specular illumination is used for most optical systems designed with an integral light source.

#### *Source to Pupil Coupling*

- Critical illumination – the light source is imaged directly onto the object.

#### *Source to Object Coupling*

- Diffuse illumination – light with a large angular spread is incident on the object. There is no attempt to image the source into the imaging system. This type of system is simple and provides uniform illumination, but it is light inefficient. This description could also include ambient or natural lighting conditions.

#### *No Source Coupling*

Note that the naming of these three classifications of illumination systems is not standardized.

### Specular Illumination

Specular illumination systems refer to systems where the source is coupled into the EP of the imaging system. Note that the term specular is not universally used for this type of system. The term Koehler is sometimes used, although this actually refers to a specific implementation.

The most common example of specular illumination is the projection condenser system. A condenser lens, placed in close proximity to the transparent object, images the source into the pupil of the projection or imaging lens.

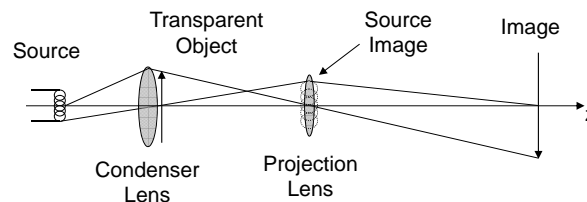

The condenser lens serves as a field lens to bend source rays going through the edge of the object back into the projection lens. The condenser lens should be designed to be as fast as possible ( $f/\#_w$  often faster than  $f/1$  on the source side). The projection lens diameter should be larger than the size of the source image.

### Need for the Condenser Lens

Without a condenser lens, the light collection angle  $\alpha$  is limited by the projection lens. Each point on the source illuminates only a section of the transparency, and non-uniform illumination can result. Only object points directly between the source and the projection lens will be projected. A small source would project only the center of the image.

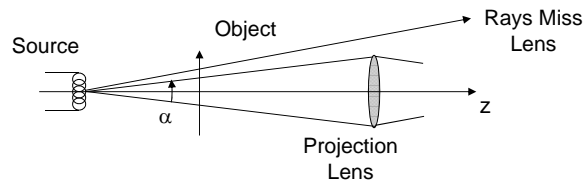

The amount of the source energy that is collected and used is defined by the solid angle given by the angular size of the projection lens  $\alpha$ .

### Uniformity and Light Efficiency

With a condenser lens, each point on the source illuminates all points on the object, and each point on the object is illuminated by the entire source. As a result, very uniform illumination can result regardless of the source size or geometry. There is no requirement on the source size to project the entire object.

The collection angle  $\alpha'$  is limited by the condenser lens size (or the object size). A greater fraction of the source energy is collected. All the light collected by the condenser passes through the projection lens.

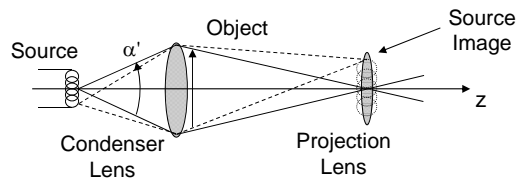

### Apparent Source Size

With a bare source, the apparent source size is limited by the angular size of the source. This defines the angular range of the illumination at the object.

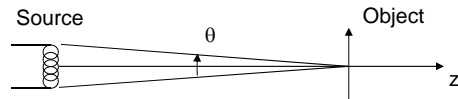

With a condenser – the same apparent angular source size results.

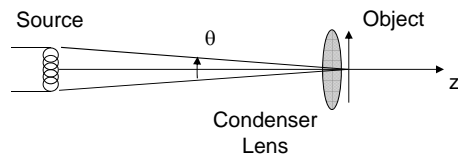

With a diffuser – all angles are present – the source appears to be large.

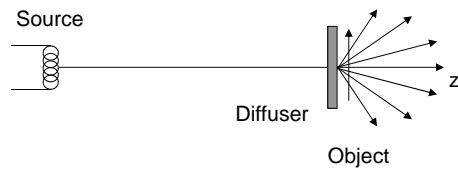

### Projection Condenser Design

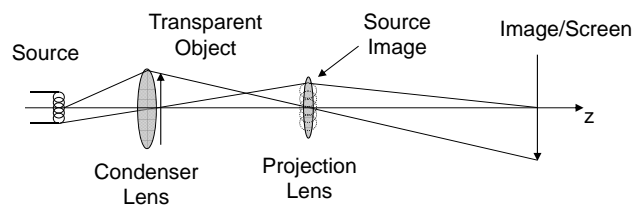

- The projection lens focal length and the object-image distances are determined by the screen position and size and the object size (magnification and object-image distance).
- The condenser lens diameter is determined by the object size and any needed separation between the condenser lens and the object. Pick a condenser lens  $f/\#$  (usually as fast as possible). The condenser focal length can then be found.
- The source position places the source image in the projection lens.
- The projection lens diameter must be larger than the source image size. This determines the  $f/\#$  of the projection lens.

The aberrations of the condenser lens need not be well corrected as its purpose is only to image the source into the aperture of the projection lens.

### Coupled Optical Systems

21-9

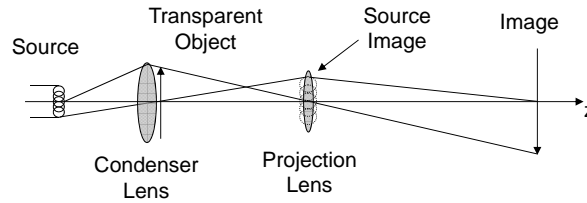

Since the condenser lens images the source into the pupil of the lens, the source is conjugate to the pupil, and the condenser can be thought of as a field lens.

The projection condenser system can be considered to be two coupled optical systems. The marginal ray of the condenser system becomes the chief ray of the imaging system, and the chief ray of the condenser system becomes the marginal ray of the imaging system.

Specular illumination is the most commonly used form of illumination in optical systems with integral sources.



### Koehler Illumination

21-10

Koehler illumination is a type of specular illumination often used in microscopes to provide control of the illumination. An intermediate source image is produced. The substage diaphragm (at the source image) allows the overall light level to be varied by changing the amount of the source that is used, and the field diaphragm changes the amount of the object that is illuminated.

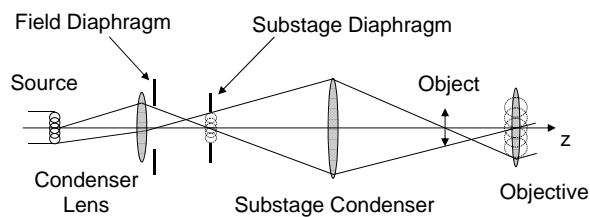

Using the substage condenser to change the source size and the illumination level is preferable to changing the voltage or current applied to the source. With tungsten filaments, changing the voltage or current also changes the color or color temperature of the light.



### Critical Illumination

Critical illumination images the light source directly onto the object. While very light efficient, critical illumination is rarely used. The source brightness distribution is superimposed directly on the object and therefore also appears as a brightness modulation of the image. A very uniform source is required; an example is a tungsten ribbon filament. The field of view of this type of system is typically small.

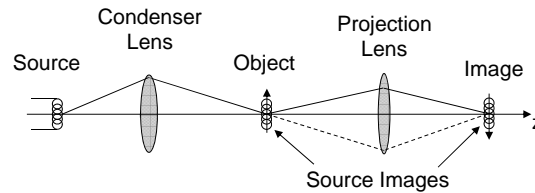

### Diffuse Illumination

Diffuse illumination is usually achieved by the insertion of a diffuser into the system. Very uniform illumination can be achieved, but these systems tend to be very light inefficient.

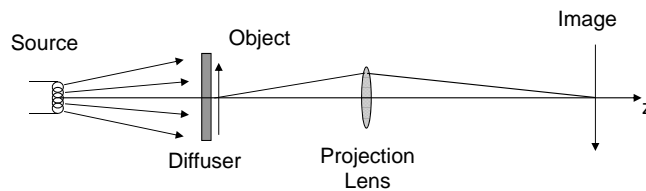

The diffuser increases the apparent size of the source resulting in greater uniformity of illumination.

Diffusers are commonly made of ground glass or opal glass. Other materials such as white or translucent plastic and drafting film are also used. The diffuser is transilluminated and placed behind the transparency. The light efficiency and degree of diffuseness depends on the material choice.

### Ground Glass and Opal Glass

Ground glass diffusers are formed roughening or grinding the surface of a glass plate. The surface becomes a random “prismatic” structure. Different grinding grit sizes can be used to produce coarse or fine ground glass. The light distribution depends on the details of the grind, and this distribution is often peaked in the forward direction. Ground glass is also used as viewing or focusing screens in cameras.

Opal glass is a glass plate where one surface has been flashed with a thin milky-white coating. The white color is produced by dispersing crystallites such as fluorine compounds into the volume of the coating. The light distribution from opal glass can be close to uniform or Lambertian. Because of the thickness of the opal coating, multiple scattering can occur and a large fraction of the light is directed backwards.

Surface diffusers, such as ground glass, tend to be more efficient and less uniform than volume diffusers, such as opal glass or translucent plastic sheets.

### Scratch Suppression

This greater range of illumination angles present with diffuse illumination provides scratch suppression that will hide phase errors on the object, such as a scratch or defect in the substrate of the object transparency.

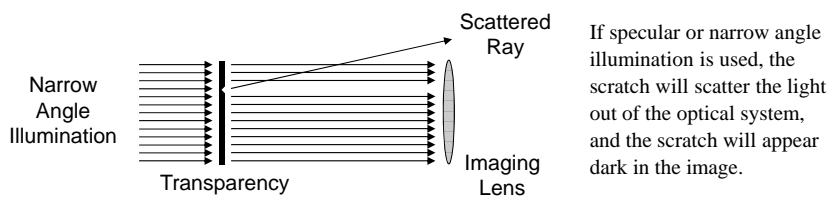

With diffuse illumination, many different input angles are present, and while some rays are scattered out of the system by the scratch, other rays will be scattered into the aperture of the imaging lens. The visibility of the scratch in the image is significantly decreased.

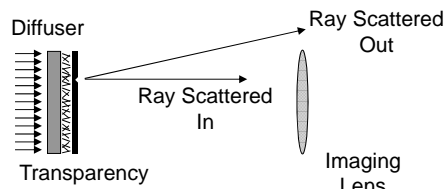

A scratch or defect in the transmission of the object is not hidden even by diffuse illumination. For example, a scratch in the emulsion of a transparency becomes part of the object and will be seen in the image.

### Integrating Bars

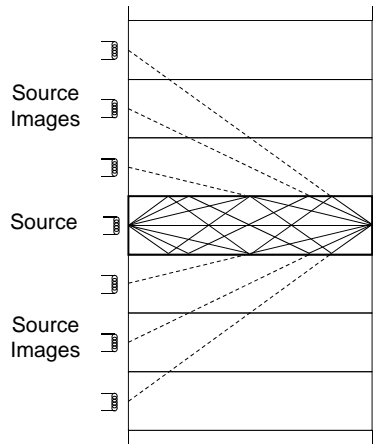

An integrating bar or light pipe provides diffuse light with a significant increase in efficiency over simple diffusers. The bar has a rectangular cross section with polished surfaces. The source is placed at one end of the bar, and TIR occurs at each face. The tunnel diagram shows that the transparency at the other end of the bar sees a rectangular (2D) array of source images. The effect is similar to a kaleidoscope. A greater range of illumination angles or diffuseness results. The bar geometry and the TIR critical angle limit the number of source images. With six polished faces, integrating bars are expensive. Diffusers can also be placed over the input and/or output ends of the bar to further increase the diffuseness. Hollow mirror tunnels can be used instead of solid glass.

### Tapered Integrating Bars

The integrating bar can also be tapered to increase or decrease the size of the source relative to the transparency. In this case, the source images appear on a sphere, and there is some loss of TIR for the outside images as the angle of incidence decreases with multiple bounces. The number of source images is reduced.

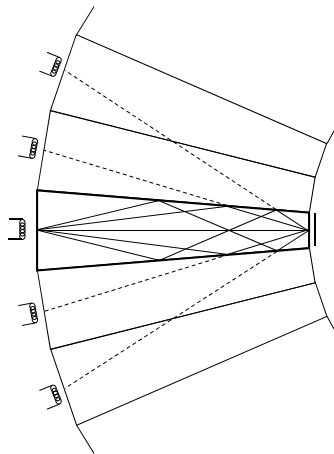



### Integrating Sphere

21-17

The ultimate in diffuse illumination is provided by an integrating sphere. The inside of a hollow sphere is coated with a highly-reflective diffuse white coating. Light directed into the entry port undergoes many random reflections before escaping through the exit port. The output light is extremely uniform with a brightness that is independent of viewing angle. It is a very good approximation to a Lambertian source. This system is also extremely light inefficient. The two ports are usually at 90° to prevent the direct viewing of the source and the first source reflection. Integrating spheres are also used in precision measurement radiometers by replacing the source with a detector.

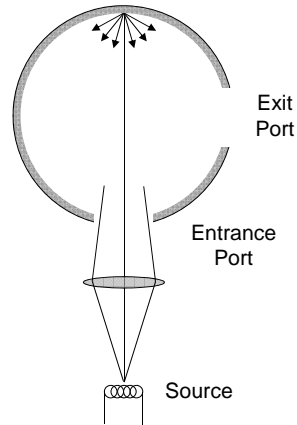

### Concave Source Mirrors

21-18

Placing a concave mirror behind the source can increase the light level in the projection system. The classic solution is to place the source at the center of curvature of the mirror. Light that was originally heading out of the system is redirected back into the system. The source image is placed on top of or adjacent to the source. An improvement of less than a factor of two is obtained.

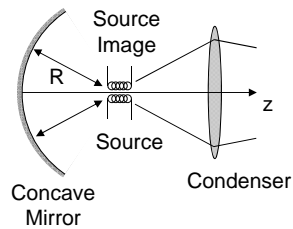

### Heat Management

Heat management is a significant issue for most projectors. Heat absorbing glass or a hot mirror can be placed between the source and the condenser lens. In addition, a concave cold mirror can be added behind the source to allow the heat or infrared IR radiation to exit out the back of the system.

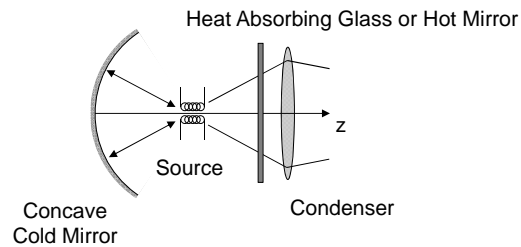

A hot mirror reflects the IR light (the hot) and transmits the visible light.

A cold mirror reflects the visible light (the cold) and transmits the IR light.

A cooling fan is often required to supplement the heat management in the optical system.

### Parabolic Reflectors

Dramatic increases in illumination level occur by placing the source at the focus of the concave mirror. The source image occurs at infinity. The designs of systems of this type almost ignore the forward light through the condenser. The mirror shape is usually parabolic. The  $f/\#$  of the condenser lens does not influence the light collection efficiency.

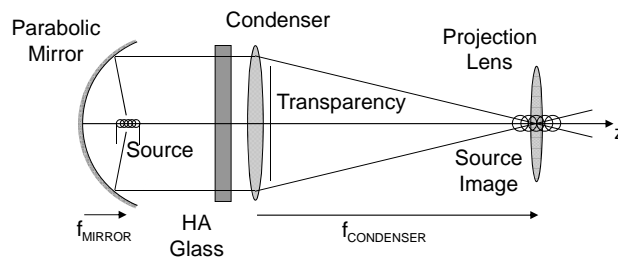

The source can be located deep inside the parabolic mirror (at its focal point), and the solid angle of the mirror can be more than  $2\pi$  sr. The amount of light intercepted and reflected by the mirror can exceed the light directly collected by the condenser by a factor of ten or more.

With a parabolic concave mirror, two source images are formed:

The direct light from the source imaged by the condenser lens.

The source image produced with the reflected light.

### Faceted Reflectors

With the smooth reflector, there is little diffuseness, and there will be non-uniformity in the illumination due to the shadow of the light bulb in the reflected light.

To provide a greater level of diffuseness, the surface of the parabola can be segmented into small flat mirrors. A virtual source is formed behind each facet. These source images are located in a plane behind the vertex of the reflector. The details of the faceted parabolic reflector are complicated, but for design purposes it can be modeled as an extended source located at or near the concave mirror.

The mirror aperture defines the extent of the extended source. The condenser lens images the aperture into the pupil of the projection lens. The projection lens aperture should match this image.



21-21

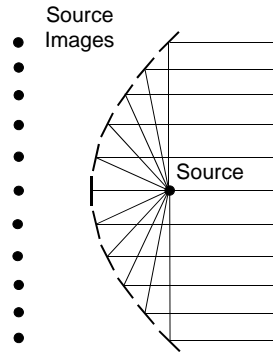

### Faceted Reflector Design

21-22

The light from each source image is directed forward through the aperture defined by its facet. In addition, the light bulb will block some of the light from the center of the reflector.

The number, size and tilt of the facets are designed so that uniform illumination is achieved at the object transparency. The overall "shape" of the reflector can deviate from a parabola.

The design of the reflector utilizes the light coming out of the side of the light bulb.

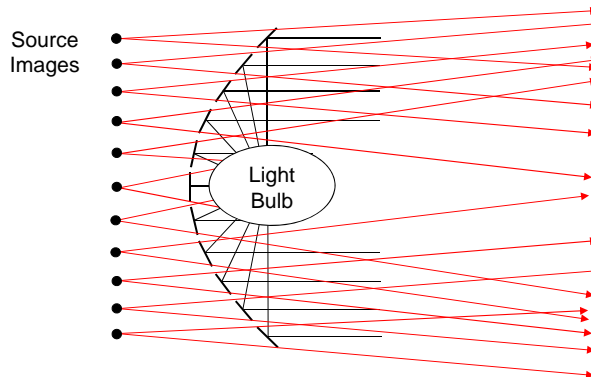

### System with the Facet Reflector

The transparency or condenser system views the individual source images through the windows formed by the respective facets on the reflector. The total view is limited by the overall aperture of the reflector. This overall aperture is imaged into the projection lens.

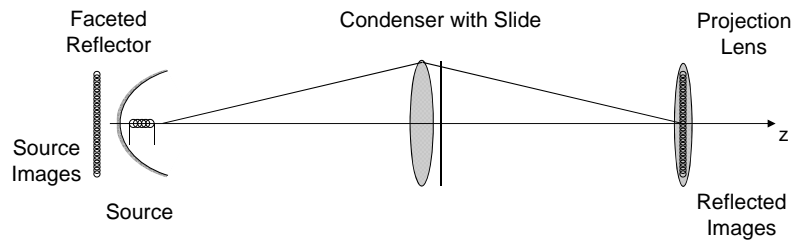

A direct image of the source is also formed. Because of the difference in the solid angles of the reflector versus the condenser lens, the direct image contains much less light.

### Light Collection Efficiency

The light collection of a parabolic reflector greatly exceeds the collection by the condenser lens in the classic projection condenser system. The amount of light is determined by the solid angle of the collection or condenser optics as seen by the source.

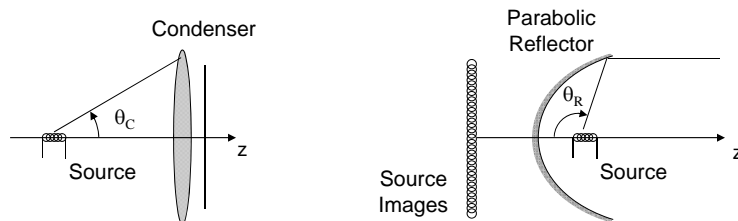

$$\Omega = 2\pi(1 - \cos \theta_0) \quad \theta_0 = \text{Half Angle}$$

Condenser or Classic System: Assume an  $f/1$  collection angle:

$$\theta_0 = \theta_C = 30^\circ \quad \Omega_C = .842 \text{ sr}$$

Parabolic Reflector: The source is inside the parabola. Assume  $\theta_R = 110^\circ$ :

$$\theta_0 = \theta_R = 110^\circ \quad \Omega_R = 8.43 \text{ sr}$$

The exact gain is difficult to estimate due to factors such as filament geometry and bulb shadowing.

### Illumination Issues

In many applications the image quality of diffuse illumination is required, but the throughput of specular illumination is needed. A larger light bulb is not always an option (A major rule of optical engineering is that there is never enough light!!). The system should be designed as specular illumination with a little diffusion added. For example, one side of the condenser lens might be lightly etched or a weak ground glass added. In these systems, be sure to design them as specular first and then add diffusers.

The filament in a light bulb is a 3D structure. It is often a coil of a coil of tungsten wire. Because of this structure, the filament itself may shadow other parts of the filament. This filament shadowing can result in non-uniform illumination.

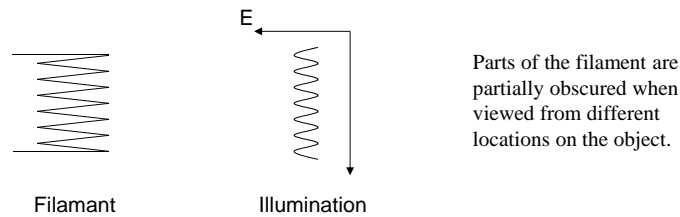

### Elliptical Reflectors

An elliptical reflector can be used to focus the source into a small aperture. The source is placed at one focus of the ellipse, and a real image is formed at the other focus. An example is coupling light into a fiber optic bundle.

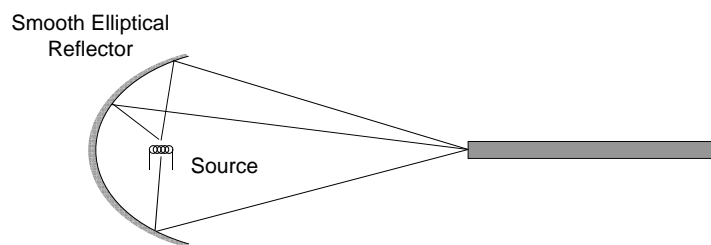

### Overhead Projector

21-27

The overhead projector uses projection condenser illumination to project a large transparency onto a projection screen located behind the presenter. In addition to bending the light path, the fold mirror creates the proper image parity for the audience. Because of the large size of the transparency, a conventional condenser lens is impractical and a Fresnel lens is used. The thick lens is collapsed into radial zones. An image is produced by each zone, and these images add incoherently, so that the diffraction-based resolution is that of a single zone.

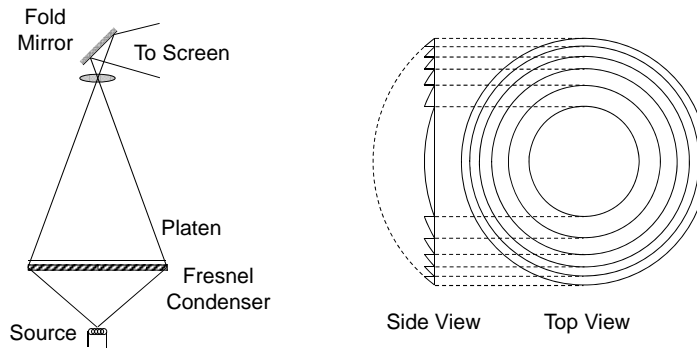

To determine parity, the diffuse reflection from the projection screen introduces a parity change like any other reflection.



### Reflection-Based Overhead Projector

21-28

A more compact overhead projector can be produced by using a Fresnel mirror instead of a Fresnel lens. The reflection system suffers from image doubling if the transparency is not in contact with the Fresnel mirror. Another serious problem is that density doubling occurs when displaying grayscale transparencies (the light goes through the transparency twice).

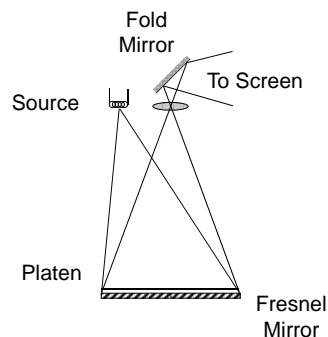

### Schlieren Systems

Narrow angle illumination can be used to identify features or defects on an object. In a schlieren system, light from a small source is collimated before passing through the object plane. An imaging lens forms an image of the source as well as the final image. The image of the source is blocked by an opaque disk or a knife edge. With no object present, the image appears black. When the object is inserted, any feature or imperfection on the object will scatter (or refract or diffract) some light past the obscuration. These localized areas on the object will appear bright in the image.

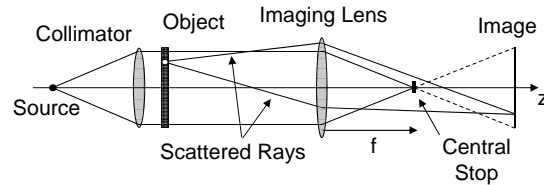

Some applications of the schlieren technique are aerodynamic flow visualization and inspecting glass for inhomogeneity and stria.

This system can also be interpreted through Fourier optics as a high-pass filter which removes the undeviated light, leaving only the light passing through areas of the object with high spatial frequency variations.

### Schlieren Images

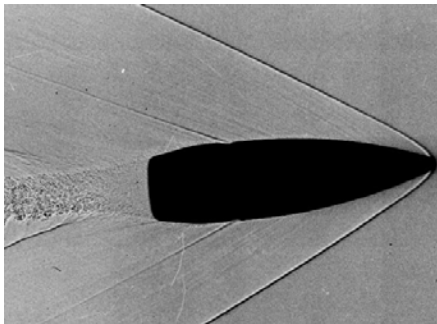

Schlieren is a German term meaning “streak”

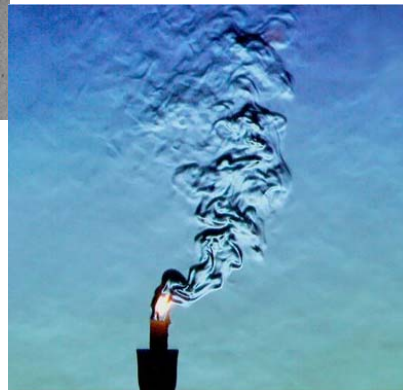

Gary Settles, University of Pennsylvania

Dark Field Illumination

Dark field illumination is another technique using directional lighting. The light source is placed to the side of the objective lens, or in a ring around the lens. If the object is perfectly smooth (a mirror), a specular reflection within the FOV of the objective misses the objective aperture, and the image is dark. Features or imperfections on the surface will scatter light into the objective and appear bright in the image. This technique is especially common in machine vision and reflection microscopy. Setups for transmission dark field measurements also exist.

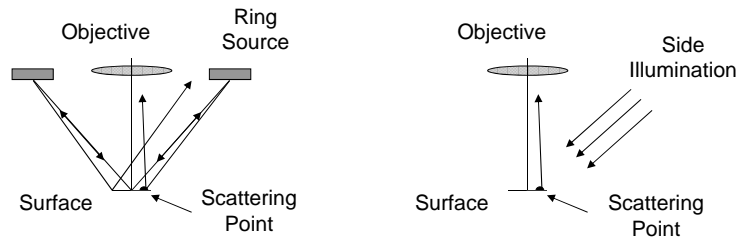

With both dark field and schlieren techniques, the orientation of features, or the surface derivatives, can be measured using an oriented knife edge (schlieren) or by directional illumination (dark field).

Bright Field and Dark Field Images

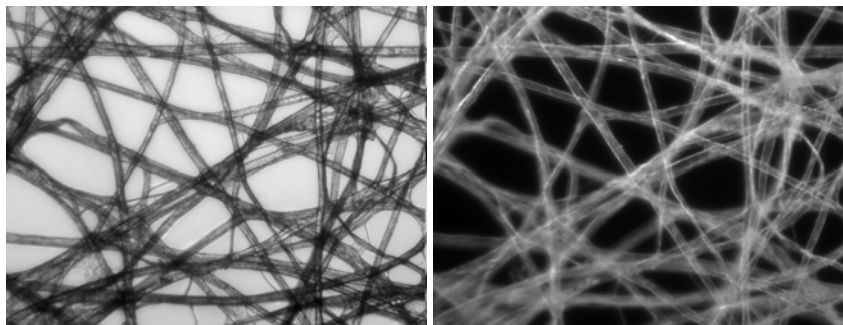

Tissue Paper Fibers - Wikipedia

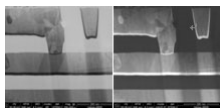

www.ma-tek.com

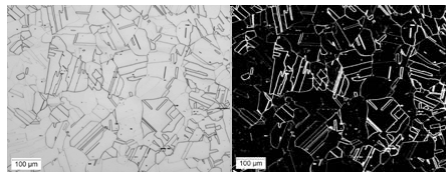

Grain Boundaries - www.carttech.com



### Non-Sequential Raytracing

Sequential Raytracing traces rays through a system in optical order according to the prescription. At each surface, reflection or refraction occurs. It is used to design, optimize and tolerance systems of lenses and mirrors.

Non-Sequential Raytracing use a three-dimensional model of the system. Rays are launched from a source and they propagate until they hit something. At the surface, the ray can be partially transmitted, partially reflected and/or scattered according to defined surface properties. The surface can be a lens mount as well as a lens element. The input ray is split into a number of rays, and these “daughter” rays each propagate until another surface is encountered. A ray can encounter surfaces in any order and any number of times.

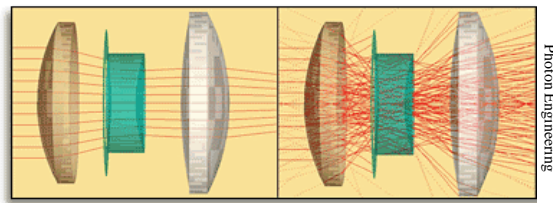

Photon Engineering

### Non-Sequential Raytracing

Non-Sequential Raytracing follows the physical trajectories of rays as they interact with the optical system. The rays are not constrained by a predetermined order of surfaces.

Important applications of non-sequential raytracing include:

- Illumination design
  - Projectors
  - Automotive and architectural
  - Backlighting
- Stray or scattered light analysis
- Ghost images/Lens flare
- Source modeling

Weightings can be applied to account for the percentage of light associated with each resulting ray.

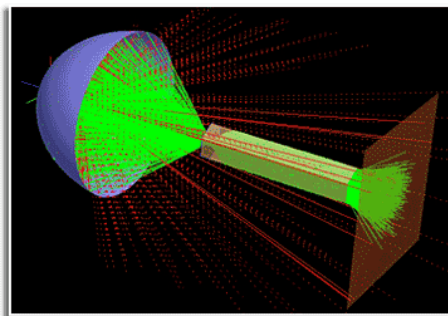

Reflector and Integrating Bar

Photon Engineering

Example – Automotive Reflector

21-35

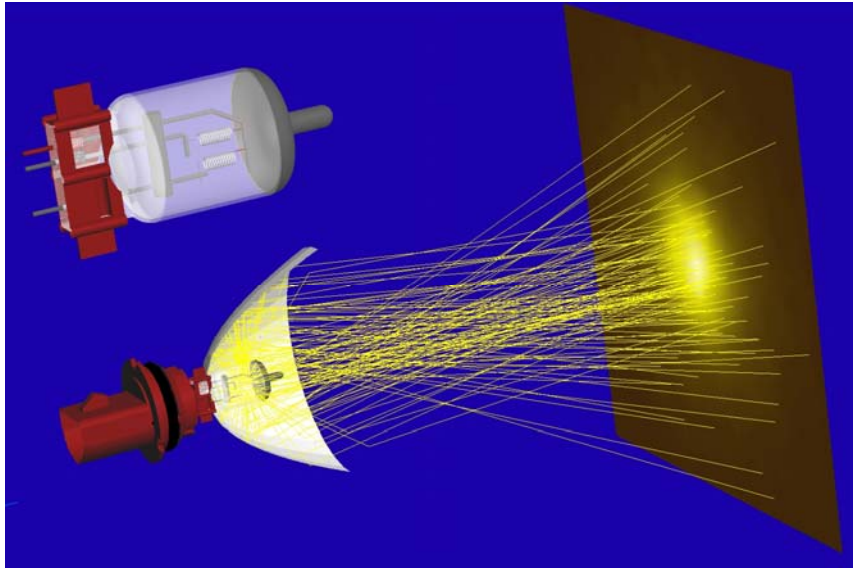

Photon Engineering



Scene Simulation

21-36



© Optical Research Associates

Roadscene with Headlights and LED Streetlights

Optical Research Associates



Example – LCD Projector

21-37

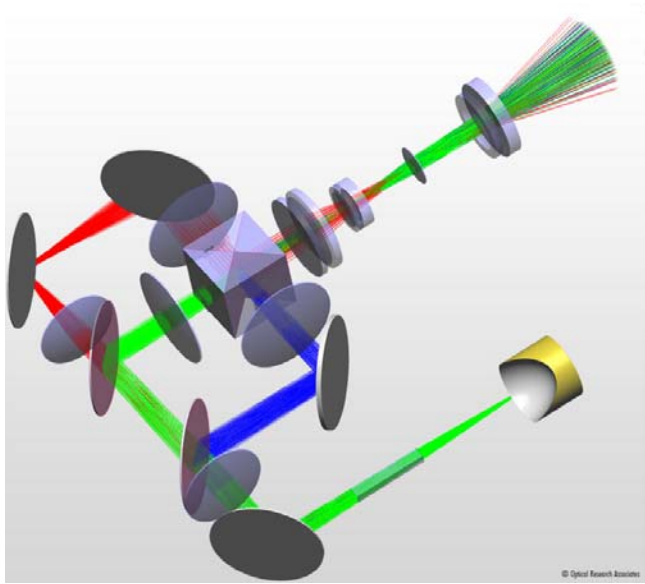

Optical Research Associates

Catadioptric Lens System – Stray Light and Baffles

21-38

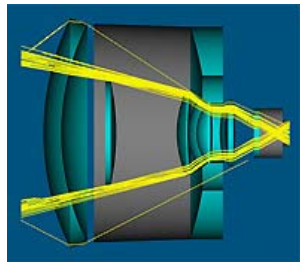

Scattering from edges of lenses and mounts

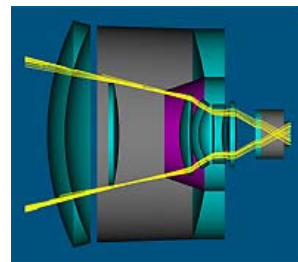

Addition of a baffle at the primary mirror.

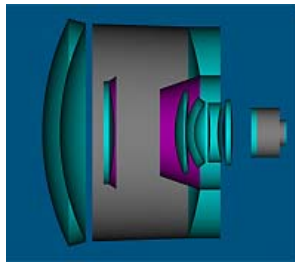

Addition of a second baffle.

<http://www.integra.jp/en/specter/applications/lens/straylight.html>

### Ghost Images and Lens Flare

Unlike the degradation of images from scattered light, ghost images are unintended images caused by specular Fresnel reflections from refracting surfaces in the optical system.

To form a ghost image, the light must reflect off an even number of surfaces, so that there are two-reflection ghosts, four reflection ghosts, etc. Because these images are out of focus, they often appear as shape of the iris diaphragm.

Ghosts are usually only formed by bright sources within or just outside the field of view. If the surface reflectivity is  $\rho$ , then the ghost will have an relative irradiance of  $\rho^N$  where  $N$  is the number of reflections. For example, a two reflection ghost from uncoated glass will have an irradiance about 0.16% of the direct image of the source producing the ghost. For AR coated glass with  $\rho = 1\%$ , the relative irradiance will be 0.01%. In addition to overall transmission, the minimization of ghosts is a good reason for high quality AR coatings on camera lenses.



www.lightworkdesign.com

Lens flare is the term applied to the combined effects of scattered light and ghost images.

